



Install your **future**

SYSTEM **KAN-therm**

**PP Green**

Ø **20-200 mm**



# About KAN

KAN is an internationally recognised Polish manufacturer of modern and comprehensive KAN-therm plumbing systems.

Since opening its business activity in 1990, KAN-therm has built its position on strong pillars: professionalism, innovativeness, quality and development. Nowadays, it employs more than 1100 people. It has a branch network in Poland and a number of international offices all over the world. The products with the label KAN-therm are exported to 68 countries on different continents. The distribution chain covers Europe, a significant part of Asia, Africa and America.



> 30

years of experience in the installation market

68

countries to which we export

> 1100

employees worldwide





SYSTEM **KAN-therm**

# PP Green

Ø20-200 mm

KAN-therm PP Green is a complete installation system consisting of pipes and fittings made from plastic – PP-R polypropylene (type 3) with a diameter range of 20-110 mm and PP-RCT (type 4) with a diameter range of 125-200 mm.

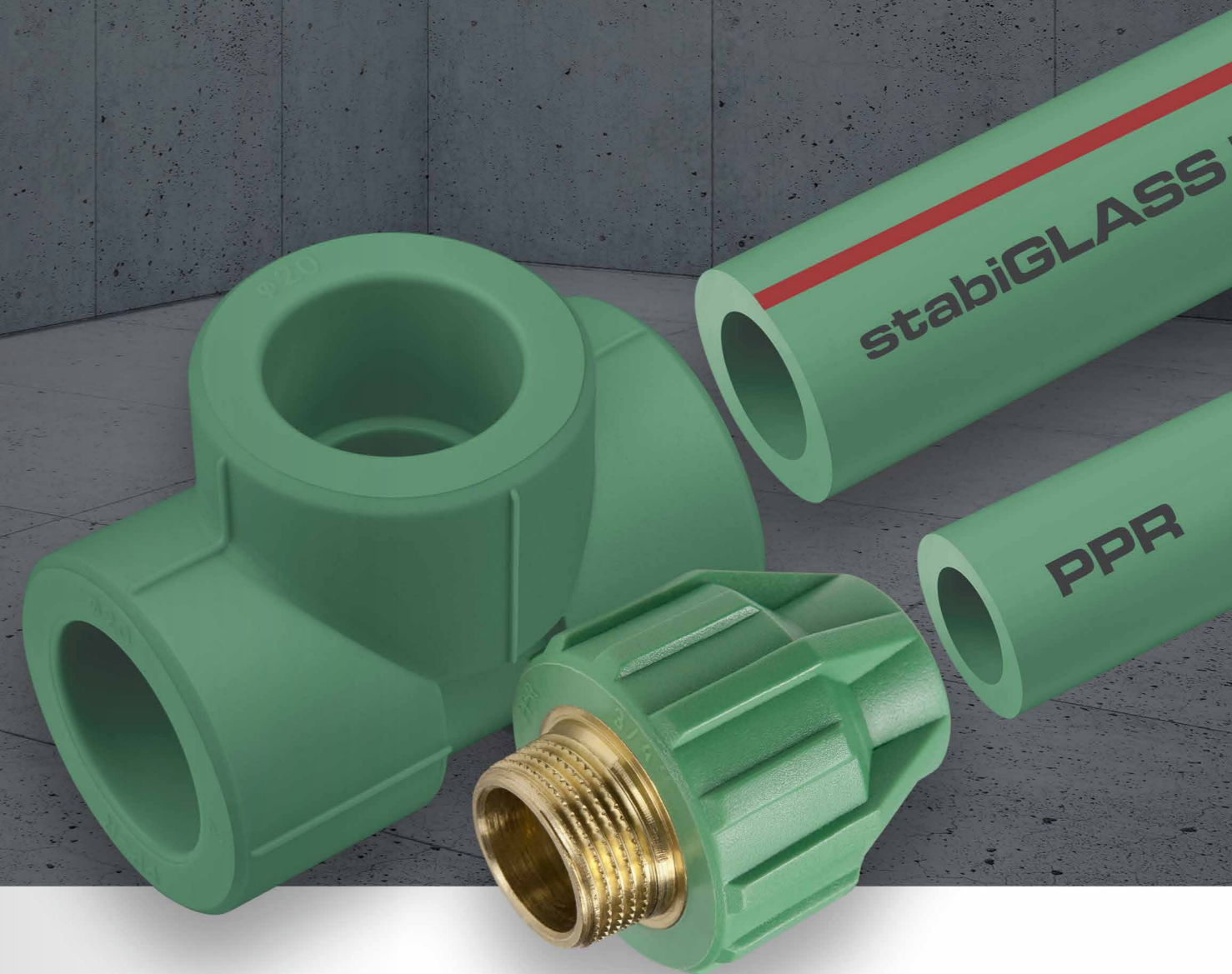

The system components are connected by socket welding, (thermal polyfusion), using electric welders. Large diameters pipelines (90-200 mm) are connected by butt welding. This welding technology creates uniform joints and therefore guarantees exceptional tightness and mechanic durability of the installation.

Complete neutrality towards potable water predisposes the system perfectly for use in indoor water supply systems. Thanks to its wide range of diameters and use of materials resistant to corrosion processes, the KAN-therm PP Green system is suitable for performing indoor heating and cooling installations in single and multi-family housings as well as public utility buildings.

The high chemical resistance of polypropylene makes the pipes and fittings made of this material suitable for the construction of systems conveying media other than water, which are often used in industry.



- 01** | Versatility of applications
- 02** | Wide pipe range
- 03** | Durable connections
- 04** | Optimal hydraulics
- 05** | Highest quality guaranteed





# Benefits

## Versatility of applications

The wide range of polypropylene components makes the KAN-therm PP Green system a viable choice for practically every type of plumbing system, starting from central heating, through domestic hot and cold water and compressed air installations, to special plants intended for handling aggressive media, as well as processing and industrial systems.

## Durable connections

Using the hot-fusion assembly technique which is polyfusion welding, the joints made are characterised by material homogeneity and achieve high mechanical resistance. The absence of any sealing parts further eliminates the risk of installation errors. The material used – a statistical polypropylene copolymer PP-R – is resistant to a wide range of chemicals.

## Optimal hydraulics

The specially modified design of KAN-therm PP Green system fittings eliminates the process of excessive flashing of material at the joint between the pipe and the fitting when welded to one another. This minimises the risk of blinding the bore during installation. Another important feature of KAN-therm PP Green fittings is the absence of bore reductions, which contributes significantly to minimising pressure losses throughout the system.

## Neutral to drinking water

The materials of the system components are physiologically and microbiologically inert in drinking water systems and do not change the chemical composition of the water, as confirmed by the PZH (Polish NIH) and QB certificates; they are also friendly to the environment and human health.

## Perfect for replacing old installations

The KAN-therm PP Green system is especially suitable for retrofitting legacy water supply and heating systems due to its wide range and completeness of components, high quality, attractive pricing, and technical and operational advantages.

## One manufacturer of pipes and fittings using the latest technologies

KAN-therm PP fittings and pipes are manufactured by a single manufacturer, using the latest plastic processing technology. The plastic pellets used in the manufacturing process come from verified and trusted sources. The material has no unnecessary admixtures like dyes, so that the finished products provide durable and robust joints.

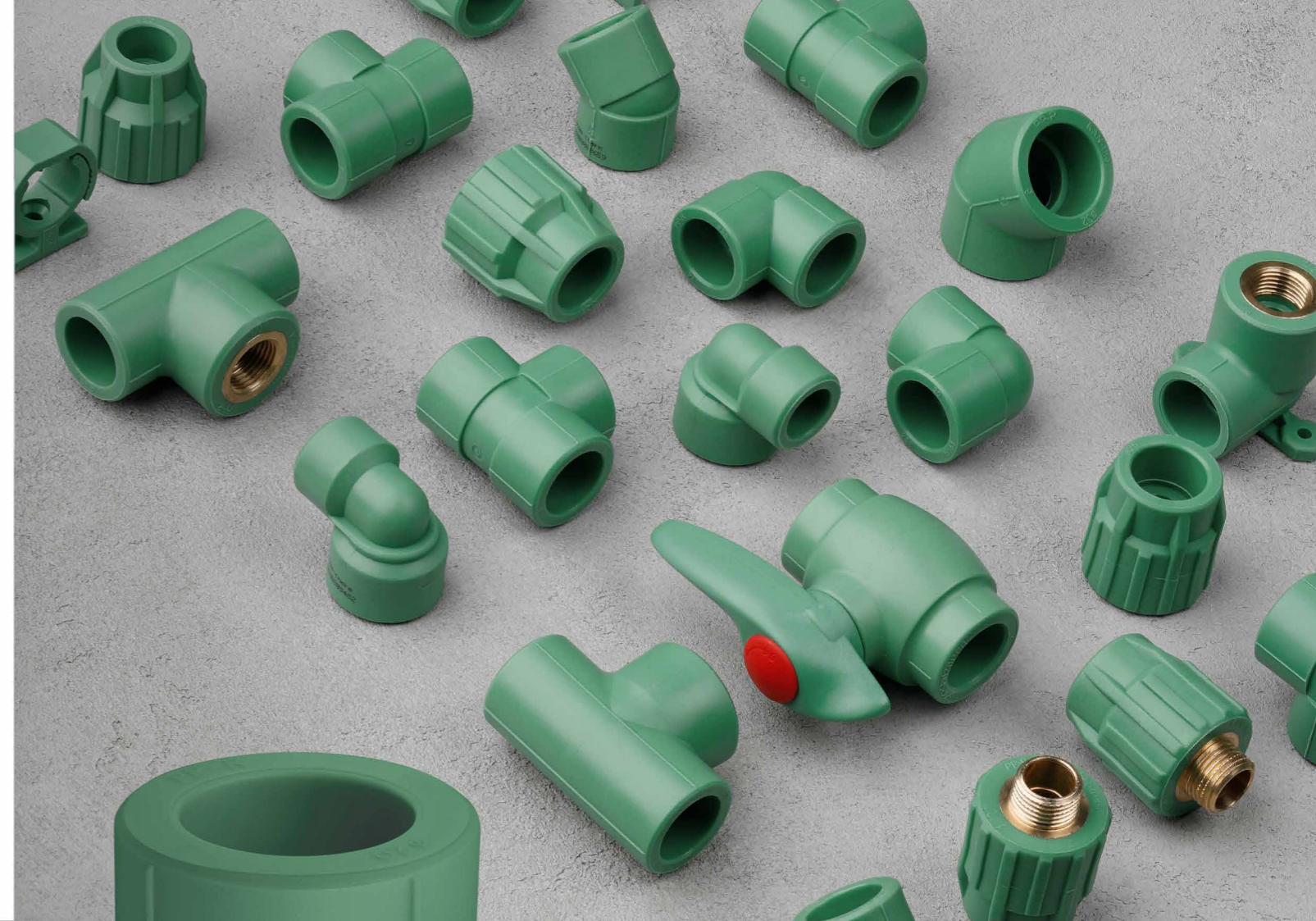

## Surface installation

Thanks to the increased rigidity of polypropylene pipes, it is possible to install surface-mounted plumbing systems with maximum aesthetic value and functionality.

## High chemical resistance

Polypropylene is highly resistant to all types of chemicals, by which the system can be applied in a wide variety of industrial and processing systems (with approval from KAN's Technical Consulting Department).

## Experience

KAN is a Polish manufacturer recognised on foreign markets, having 30 years of experience in the production of piping components for central heating and water supply systems.



# Applications

The system is designed for building complete plumbing (with supply risers and horizontal branch-off pipes) of heating, hot and cold water systems in single-family, multi-family and public buildings.

The system is especially recommended for the replacement of old, corroded steel plumbing in hot and cold water and compressed air services in multi-family and public buildings.

## KAN-therm PP Green system performance and application range in heating and water supply installations.

Application (ISO 10508)	Operating pressure (bar)	Pipe type
Domestic cold water $T = 20\text{ °C}$	Per pipe pressure rating	all pipes
Domestic hot water [Application Class 1] $T_d/T_{max} = 60/80\text{ °C}$	10	Solid SDR6 & stabiAL PPR
	8	Solid SDR7.4, stabiAL PPR & stabiGLASS PPR; SDR9 stabiGLASS PPRCT
Domestic hot water [Application Class 2] $T_d/T_{max} = 70/80\text{ °C}$	8	Solid SDR6 & stabiAL PPR; SDR9 stabiGLASS PPRCT
	6	Solid SDR7.4, stabiAL PPR & stabiGLASS PPR; SDR11 stabiGLASS PPRCT
Underfloor heating; low-temperature radiator heating [Application Class 4] $T_d/T_{max} = 60/70\text{ °C}$	10	All PPR pipes
	8	SDR9 stabiGLASS PPRCT
	6	SDR11 stabiGLASS PPRCT
Radiator heating [Application Class 5] $T_d/T_{max} = 80/90\text{ °C}$	6	All PPR and SDR9 stabiGLASS PPRCT pipes
	4	SDR11 stabiGLASS PPRCT



TAP WATER



HEATING



TECHNOLOGICAL  
HEAT



COOLING



COMPRESSED AIR



TECHNICAL GASES



BALNEOLOGICAL



# Pipes

The wide range of polypropylene pipes makes the KAN-therm PP system a viable choice for practically every type of plumbing system, starting from central heating, through domestic hot and cold water and compressed air installations, to special plants intended for handling aggressive media, as well as processing systems.



## PPR pipes

Uniform PPR pipes, requiring no additional mechanical working prior to the welding process. They are most commonly used in low- and medium-temperature systems with services like cold and hot water, compressed air or systems conveying aggressive substances.

Available ranges: **PN16 / SDR7,4 and PN20 / SDR6.**

## stabiAL PPR pipes

The stabiAL PPR pipes feature a layer of perforated aluminium foil in the pipe structure. Due to its low coefficient of thermal expansion, this type of pipe is most commonly used for high-temperature transmission systems like central heating.

Available ranges: **PPN20 / SDR6.**

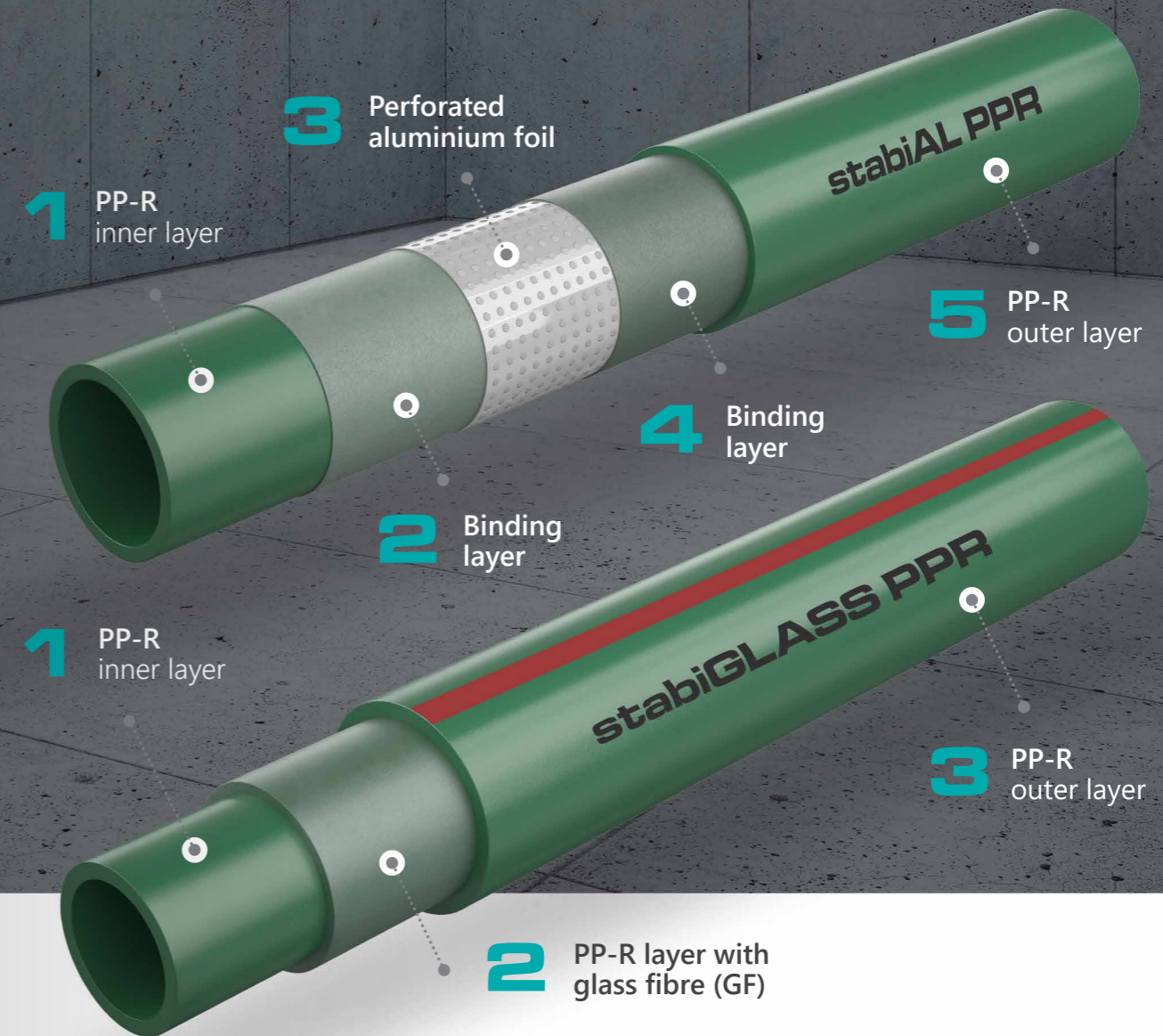

## stabiGLASS PPR pipes

The design of stabiGLASS PPR pipes combines the performance advantages of stabiGLASS PPR pipes and the convenience of assembling uniform pipes. Thanks to the glass fibre layer, the pipes do not require any additional mechanical working (by removal of the aluminium foil layer) prior to the welding process and have a low thermal expansion coefficient. The pipes are most commonly used for high-temperature transmission systems, like central heating.

Available ranges: **PPR: PN16 / SDR7, 4 PPRCT: PN16 / SDR9 and PN16 / SDR11.**

## stabiGLASS PPRCT pipes

StabiGLASS PPRCT PPRCT pipes, requiring no additional mechanical working prior to the welding process. The pipes are available in 125mm, 160mm and 200mm diameters and are most commonly used for medium transmission systems and large manifold plants.

Available ranges: **PN16 / SDR9 for 125mm and PN16 / SDR11 for 160mm i 200mm.**



# Fittings

The specially modified design of KAN-therm PP Green system fittings eliminates the process of excessive flashing of material at the joint between the pipe and the fitting when welded to one another. This minimises the risk of blinding the bore during installation.

Another important feature of KAN-therm PP Green fittings is the absence of bore reductions, which contributes significantly to minimising pressure losses throughout the system.

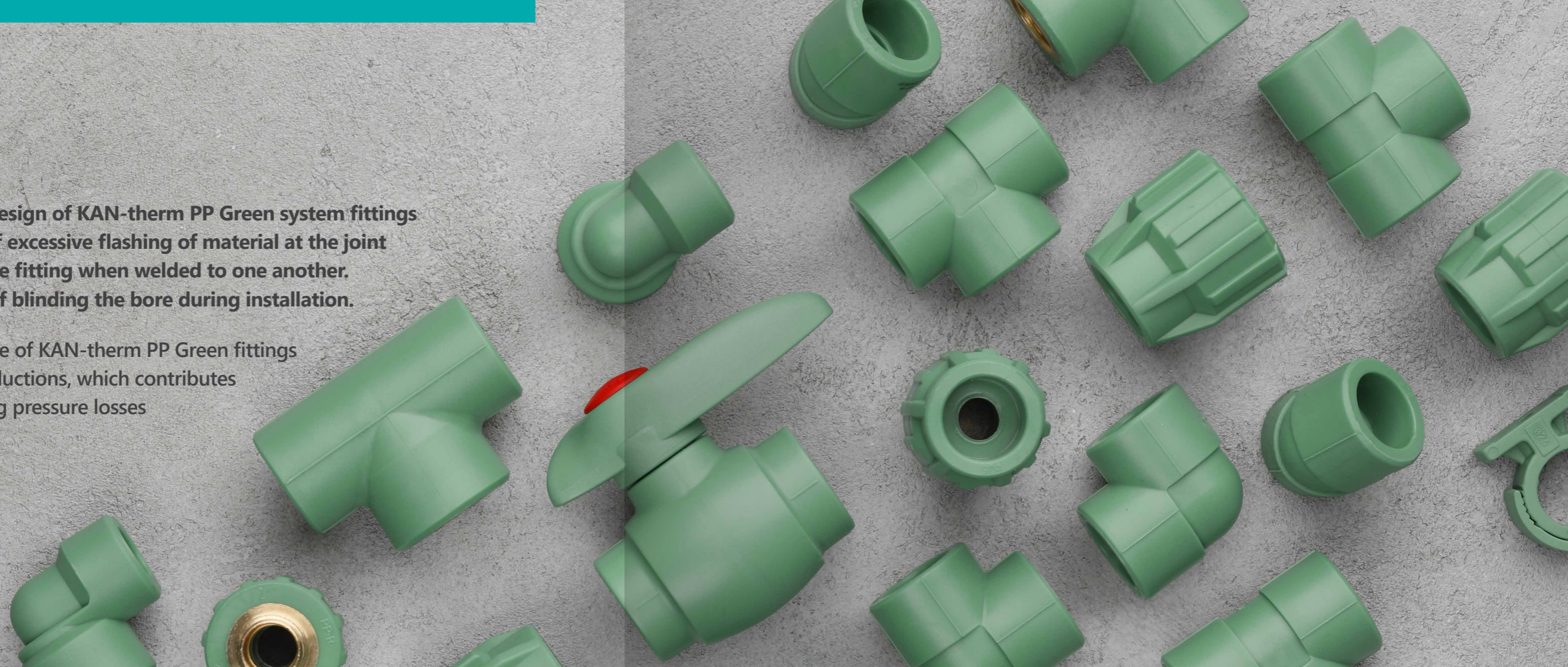

## The stopper in the KAN-therm PP design

A specially developed stopper in the design of PP Green fittings reduces the risk of inserting the pipe too deeply, which minimises the risk of completely or partially plugging the fitting bore.

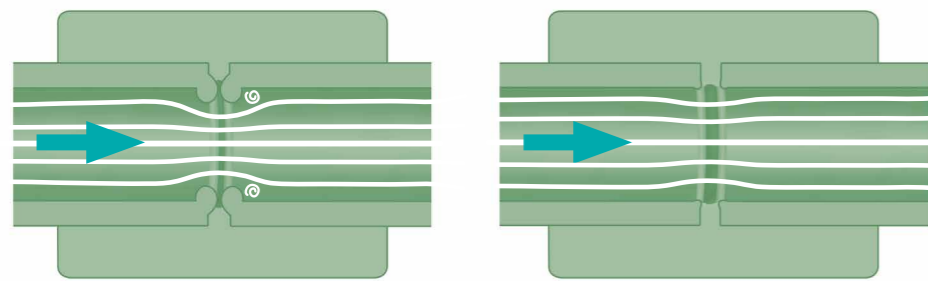

## Saddle fittings

Saddle fittings are an excellent alternative to traditional tees. They save time and money otherwise required for extra reduction pieces and making more joints. The KAN-therm PP Green range is available in several design options.

## KAN-therm PP globe valves

KAN-therm PP Green welded globe valves are an excellent alternative to traditional, failure-prone threaded globe valves. The KAN-therm PP globe valves have interchangeable inserts and are available in several design options to serve diverse needs of project owners.





# Tools

In addition to the pipes and fittings, the KAN-therm PP Green system also includes a full range of the latest connecting tools.

The correct execution of connections considerably contributes to a failure-free and long operating life of the installed system; it is why assembly tools of the KAN-therm PP Green system are thoroughly inspected and pass to stringent tests at the KAN laboratory.

Ritmo prisma JIG tool

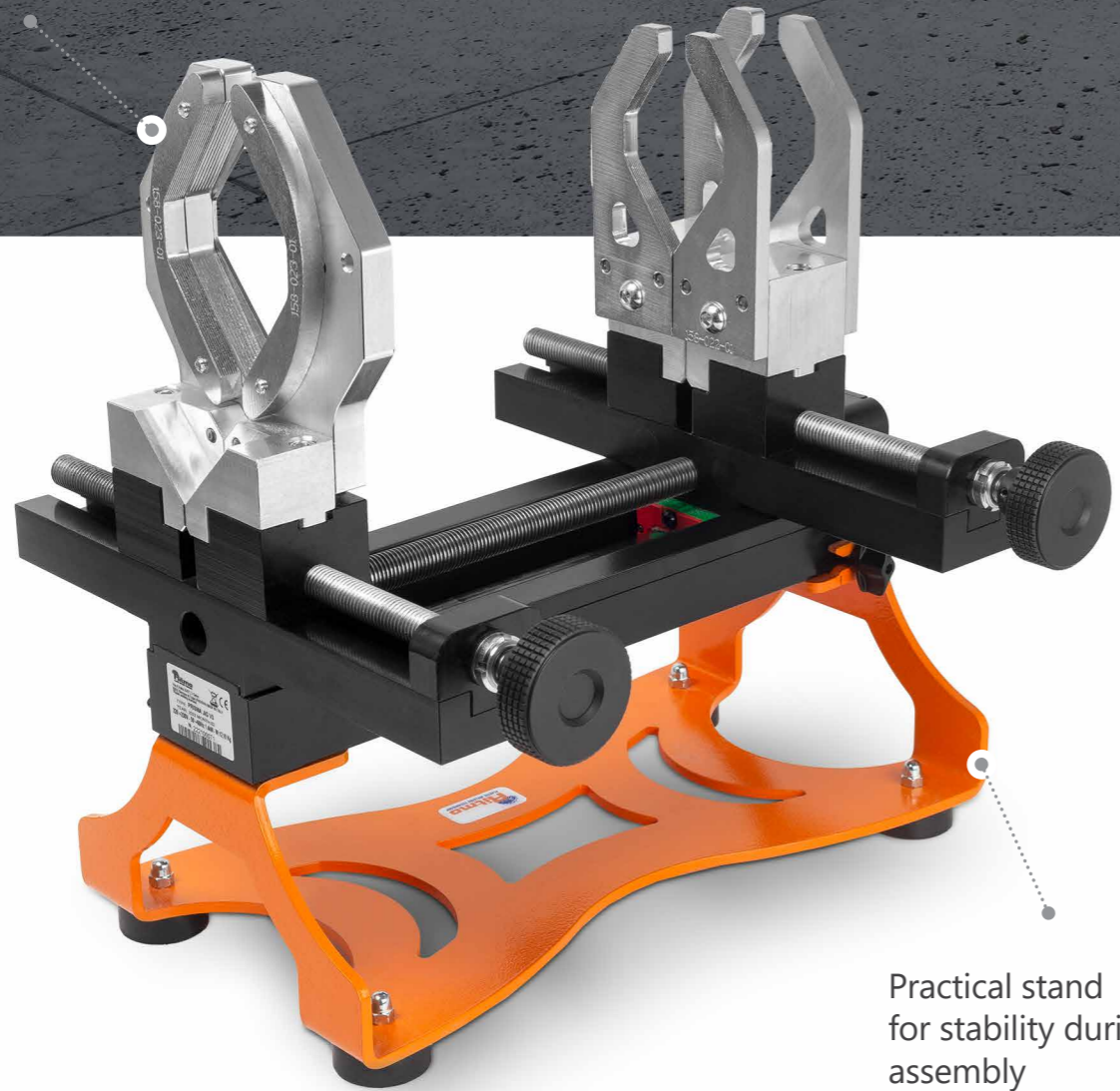

Practical stand for stability during assembly

Spider 125 McElroy tool

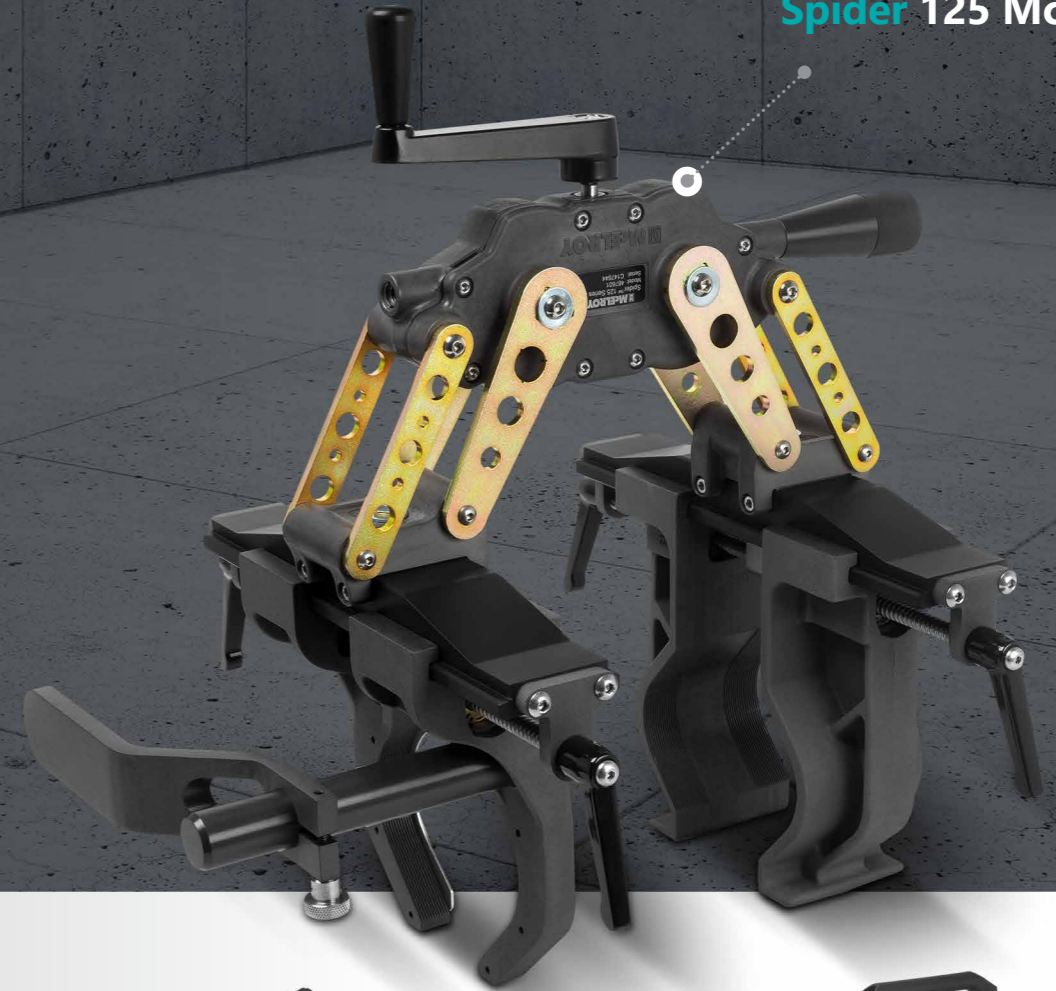

Plastic case with wheels and a handle for easy transport





The tool sets with 800W and 1600W rated welding machines include welding tips for every diameter in the portfolio.



KAN-therm **800W** welding set

Aluminium foil scraper with interchangeable blades for the stabiAL PPR piping

Welding machine 230V for 16-50 mm

KAN-therm **1600W** welding set



Plastic case with a handy measure on the exterior

Classic pipe cutter and roller cutter for piping diameters up to 110 mm



Welding machine 230V for 63-110 mm





**01** Cutting pipe with scissors.



**02** Removing the aluminium foil with the scraper (applicable to stabiAL PPR composite piping).



**03** Marking the welding depth.

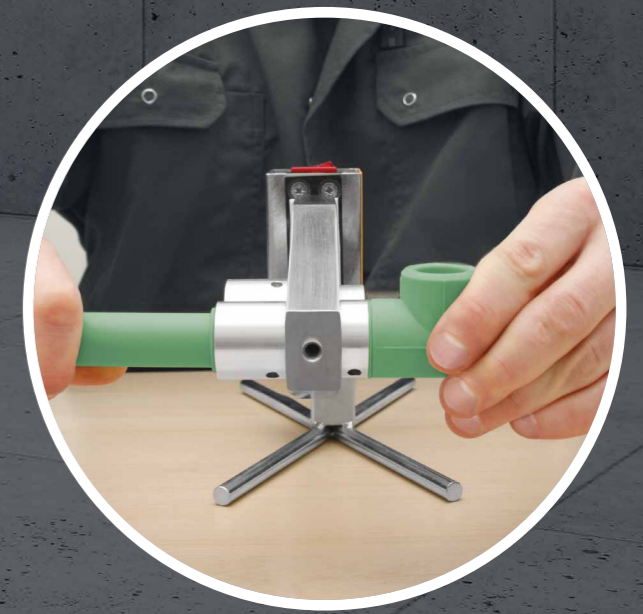

**04** Heating the pipe and fitting.

## Installation

The system components are joined by socket welding, called thermal polyfusion, using dedicated electric welding machines. The welding technique produces homogeneous fused joints to guarantee an exceptional leak-tightness and mechanical strength of the piping system.

The KAN-therm PP Green range may also feature fittings connected by electrofusion. This process is done automatically thanks to the special design of electrofusion fittings and dedicated automatic electrofusion welding kits.

The product with diameters from 90 mm to 200 mm can also be connected by butt welding. For this connection type, the KAN-therm PP Green system also supplies ready-made, dedicated welding sets.



**05** Connecting the parts.

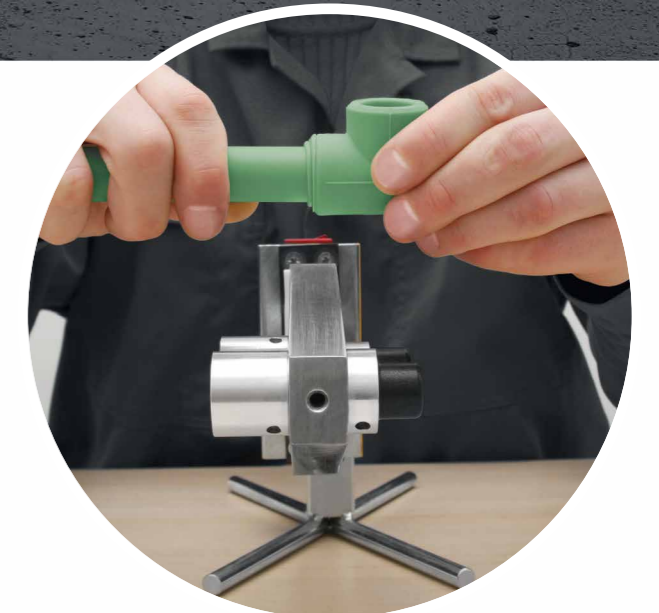

**06** Fixing and cooling down the joint.



# Sustainability

The production of KAN-therm PP Green pipes and fittings is operated in modern industrial facilities that are designed strictly with sustainability in mind and located in one of Europe's greenest regions, close to the largest UNESCO World Heritage nature reserves.

The components are manufactured using processes that minimise energy and material consumption.



**The KAN-therm PP Green system pipes and fittings are made with the highest quality granulated PP-R and PP-RCT manufactured as recommended in the ISO 14001:2004 environmental system standard.**

**The materials are free of environmentally harmful substances like chlorine or heavy metals. The products of combustion are only carbon dioxide and water vapour, without poisonous gases such as hydrogen chloride or dioxins. As a result, KAN-therm installations are also safe in the event of fire.**

The KAN-therm PP Green system pipes and fittings are used handling the most important consumable – drinking water. The high quality of the material used, the state-of-the-art, clean manufacturing technology and stringent quality control ensure that the pipes and fittings meet all – even the most stringent – hygiene standards and requirements for the quality of conveyed water.





## The best evidence of the highest quality are numerous completed projects in various sectors of the construction industry.









Despite the fact that they are not visible on a daily basis, installations made in the KAN-therm system have been working flawlessly in the largest housing estates, in public buildings, single-family houses, sports and recreational facilities, as well as in industrial halls and factories for over 30 years.

The KAN-therm PP Green system is a very well-known and widely used technical solution, which is why it can be found in various projects: from multi-family housing to large sports arenas and old listed buildings.

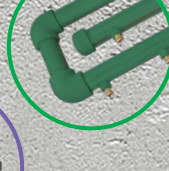

# Multisystem **KAN-therm**

Complete multipurpose installation system consisting of state-of-the-art, mutually complementary technical solutions for pipe water distribution installations, heating installations, as well as technological and fire extinguishing installations.

	ultraLINE	
	ultraPRESS	
	PP Green	
	Steel	
	Inox	
	Groove	
	Copper, Copper Gas	
	Sprinkler	
	PowerPress	
	Surface heating and cooling Control automation	
	Football Stadium installations	
	Cabinets and manifolds	

